

CHROME PLATED ZAMAC STIRRUP BRACKETS

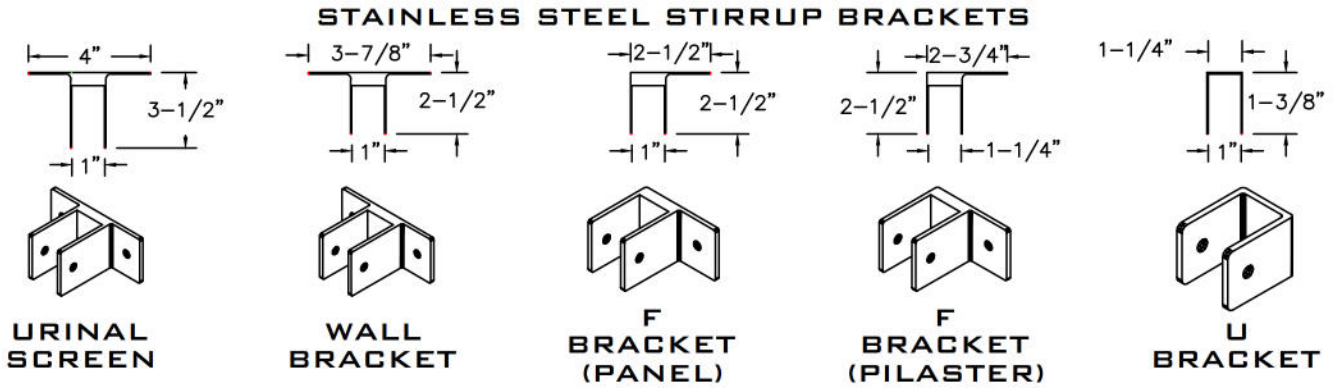

CONTINUOUS STAINLESS STEEL CHANNELS

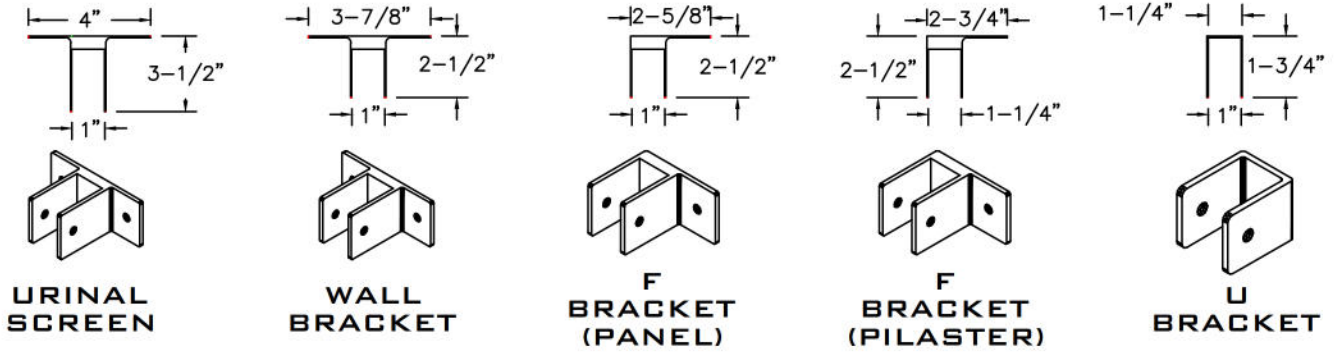
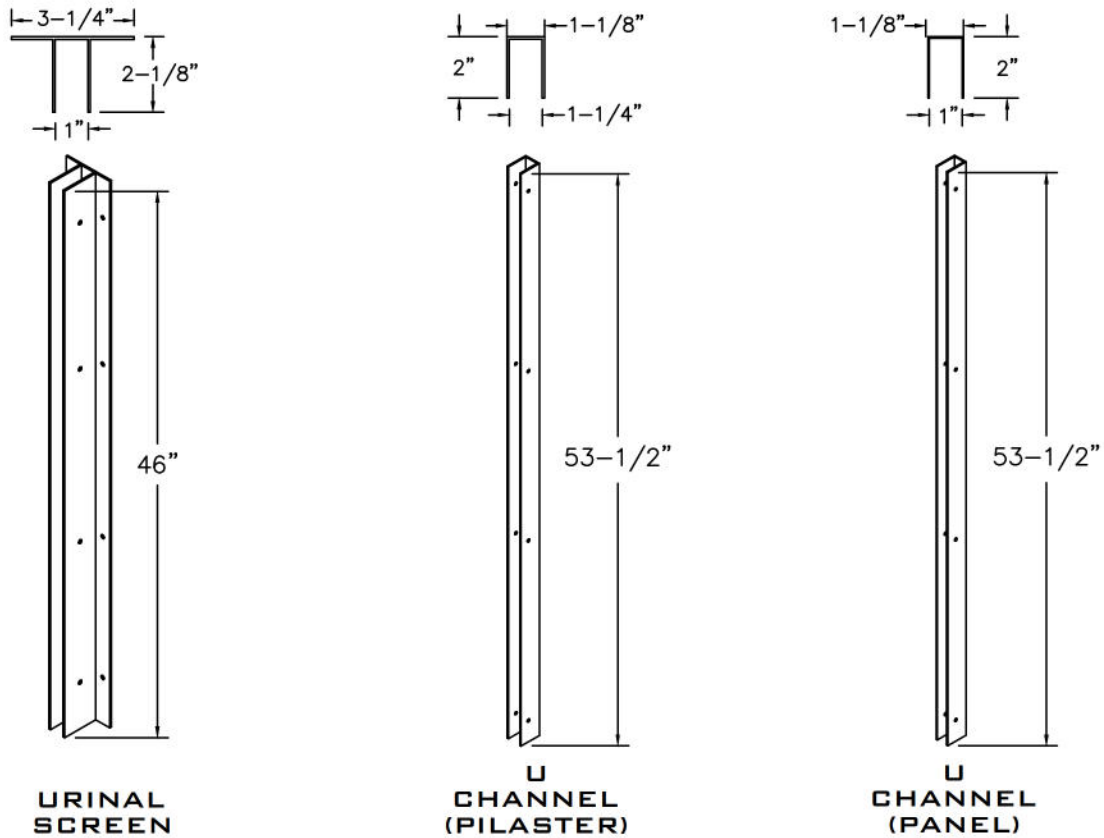

REV 01/25