

OVERHEAD BRACED

USE THESE SIZES FOR DRILLING (ALL FASTENERS ARE T27 PIN HEAD TORX)

#9 drill for #14 x 5/8" sheet metal screws

1/4" carbide drill for conical anchors

1/4" high speed drill for hinge and stop/keeper thru bolts

1 INSPECTION

The components for this project have been custom fabricated. They were inspected at the factory and all workmanship is guaranteed. Before beginning work, the units should be inspected. If damage occurred in transit, report immediately to the freight company or other agencies that may have caused the damage.

2 LAYOUT

- Review the layout drawings and package lists that have accompanied this job.
- Establish and mark pilaster center line from back wall.
- Establish and mark panel center lines for wall brackets.
- Establish pilaster floor fastener locations from side wall according to shop drawings. (Note floor fasteners are located 1" from each edge of pilaster).
- Mark wall bracket holes using brackets as templates.
- Drill holes for wall brackets and floor fastenings of appropriate size for particular fastening devices supplied.

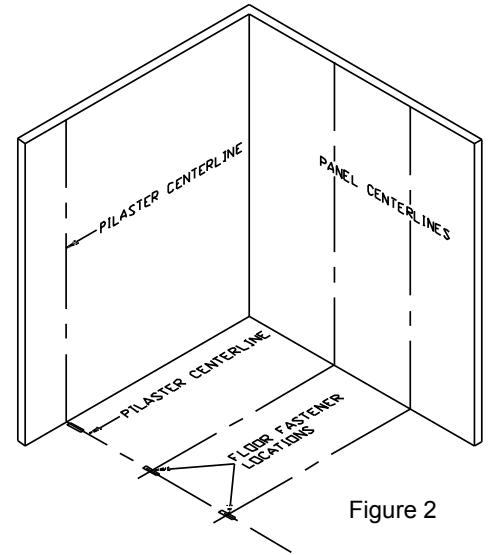

Figure 2

3 WALL BRACKETS & FLOOR BRACKETS

- Before proceeding, confirm that backing of wall and floor is adequate to support secure mounting of the toilet compartments.
- Insert shields or other floor fastening devices. Position shoe clips and mounting forks over shields and secure loosely with screws.

4 POSITION PANEL

- Place panel on a support 12" above the floor.
- Set it into wall brackets, but do not fasten panel at this time.

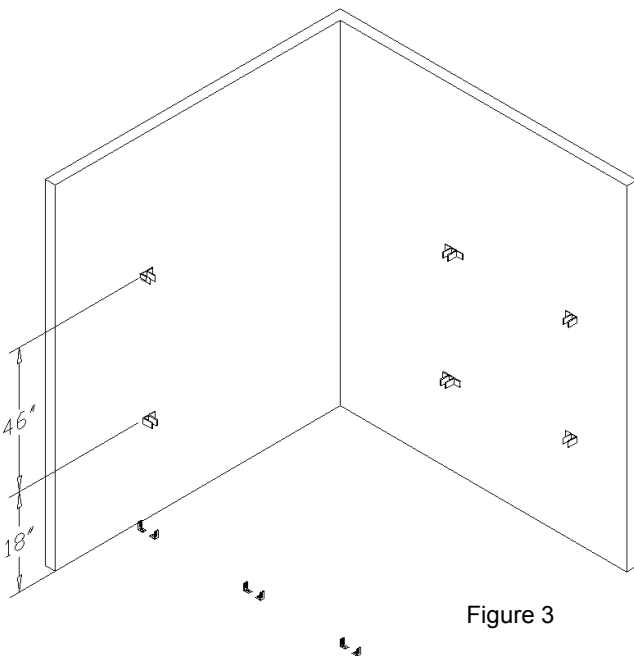

Figure 3

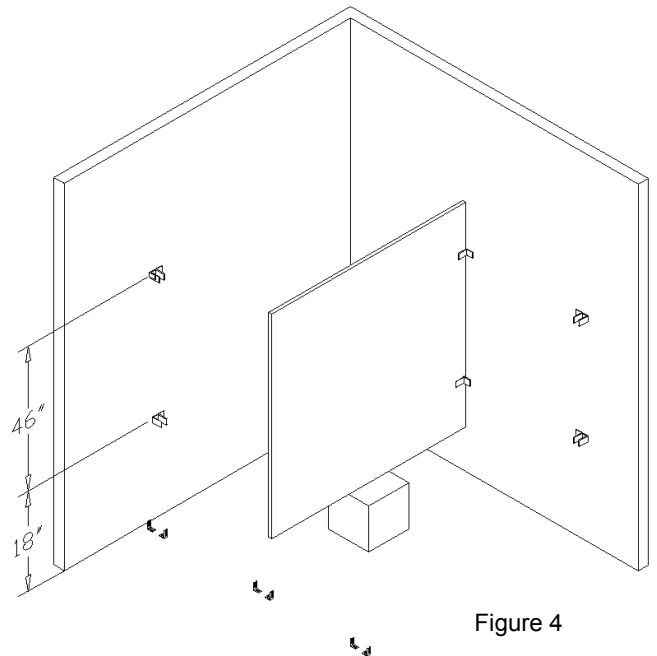

Figure 4

OVERHEAD BRACED

5 PILASTER PREPARATION

- Align U-brackets in position on rear of pilasters. Refer to layout drawings.
- Fasten U-brackets to pilasters with screws.
- Pilasters at wall do not require U-brackets, but should be prepared for wall (and floor fastening) as required by compartment layout. If floor fastening is omitted, three wall brackets should be used.

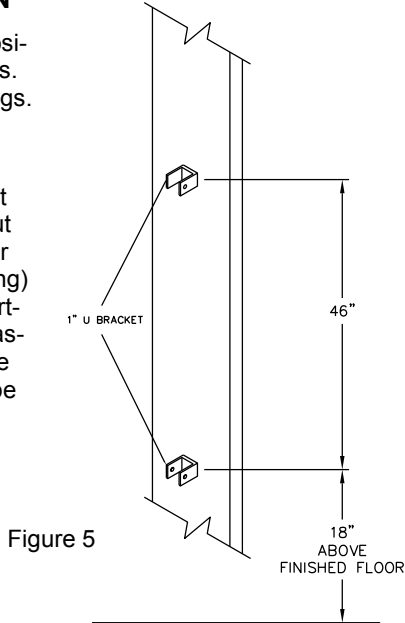

Figure 5

6 INSTALL PILASTER

- Slide stainless steel shoe carefully over mounting end of pilaster and leave approximately 5" above end.
- Place pilaster on mounting forks and fasten loosely with screws at pre-drilled locations at each side.

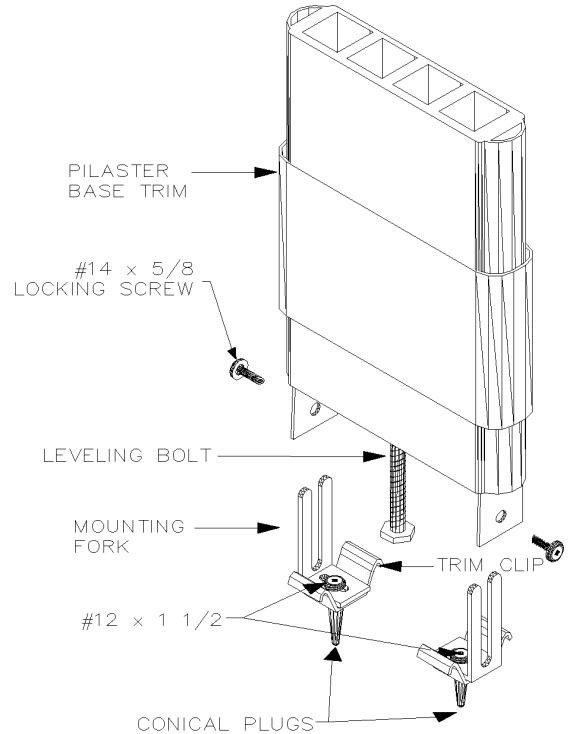

Figure 6

7 SECURING PILASTERS TO PANELS

- Pilasters must be both plumb and level.
- Plumb pilaster and fasten pilaster to panel using the sheet metal screws provided.
- Establish bottom door openings by adjusting pilaster to desired position and tightening screws.

8 HEADRAIL AND PANEL FASTENING

- Level headrail from one compartment to the next by adjusting the jack leveling bolt on the mounting at the bottom of pilaster.
- Tighten locking screws at sides of pilaster mounting bracket.
- Establish top door openings by mounting headrail and secure with screws on inside of pilaster.
- Slide stainless steel shoe down to floor level, firmly engaging shoe clips.
- Place a carpenter's level on top of panel and wedge out from rear wall until level. Attach panel to wall brackets using the sheet metal screws provided. Continue procedure for all panels.
- Remove panel support device.
- To insure rigidity, install headrail between end pilaster and wall by securing "F" brackets above end panel to surface of headrail and on opposing wall surface.

Figure 8

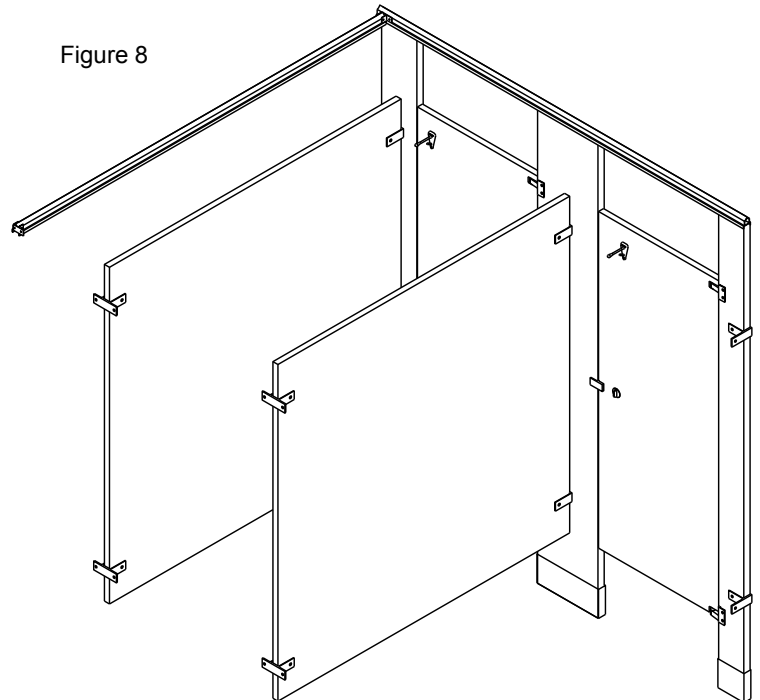

9 DOOR ASSEMBLY AND HANGING

- a. Attach top and bottom hinge brackets to pilaster with thru bolts (4-total). If pilasters were not pre-drilled at the factory, use dimensions shown in Figure 9A as a drilling ($\frac{1}{4}$ " bit) guide.
- b. Assemble cam pintle, external tooth washer, internal tooth washer, and $\frac{1}{2}$ " hex nut to the bottom hinge bracket as shown in Figure 9A and hand-tighten (to be wrench-tightened later).
- c. Insert box cam into bottom door casting as shown in Figure 9A, with short key pointing toward hinge side (edge) of door.
- d. Set door onto bottom hinge cam pintle. Bring door up so the top hinge casting is in line with the top hinge bracket as shown in Figure 9A. Insert the top hinge pintle and tap it down so it's flush with the top of the door.
- e. Set resting position of door. Hold door firmly in desired resting position (typically 20 degrees open for inswing doors and closed for outswing doors and all accessible compartment doors, regardless of swing) and wrench-tighten the $\frac{1}{2}$ " hex nut under bottom hinge bracket.
- f. Mount external plate and knob. Remove clear plastic retainer holding spring washer in place on the post of the external plate. Insert the external plate into door as shown in Figure 9B, with the shorter post inserted into the upper pocket of the internal latch mechanism. Mount the knob/handle on the inside of the door and engage it with both the center post and the shorter, off-center post of the external plate. Insert $\frac{1}{2}$ " shoulder screw with blue tip through the knob/handle and tighten until snug. Check for proper operation of knob and latch pin before final tightening.
- g. Locate strike/keeper on the latch-side pilaster so the latch pin engages with it when the door is closed. Drill ($\frac{1}{4}$ " bit) mounting holes and secure strike/keeper to pilaster using thru bolt (1), with black rubber bumper facing out for outswing doors and in for inswing doors.
- h. Mount coathook/bumper near center of door and 34"- 48" above the floor with #10 x $\frac{3}{4}$ " sheet metal screws (drill holes with $\frac{1}{8}$ " bit).
- i. Mount door pulls with 1- $\frac{1}{4}$ " step bolts (drill holes with $\frac{1}{4}$ " bit) to both sides of all outswing doors and accessible compartment doors, near the latch and no more than 48" above floor.
- j. Mount wall bumper for outswing doors that are hinged next to a wall using conical anchor (drill hole with $\frac{1}{4}$ " bit) and 1" sheet metal screw.

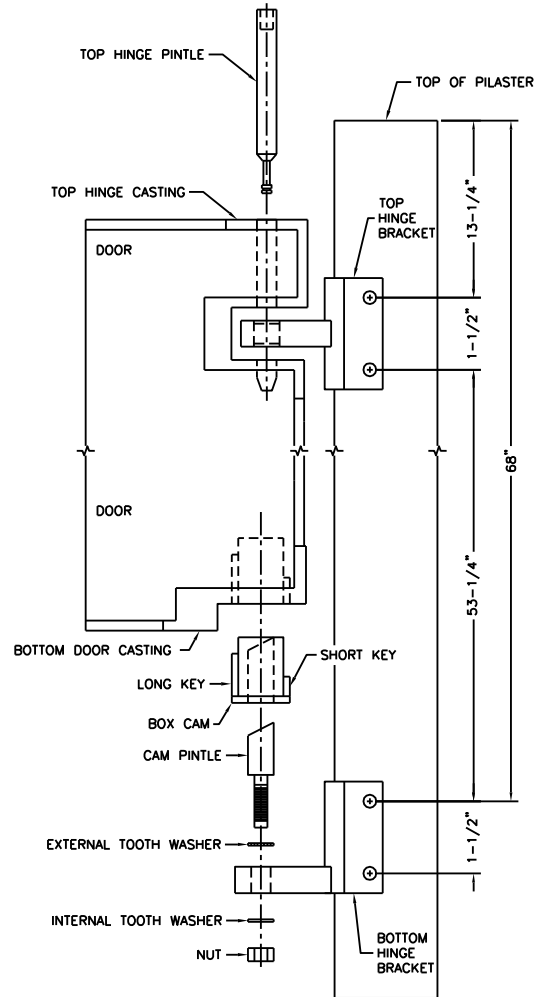

Figure 9A

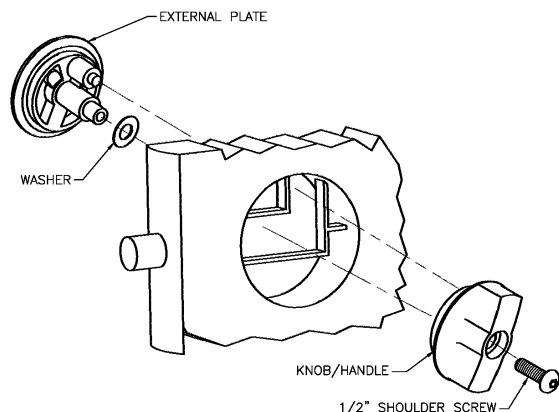

Figure 9B

OVERHEAD BRACED

10 CARE AND MAINTENANCE OF TOILET PARTITIONS

In order to provide toilet partitions with the proper care and maintenance, the following instructions must be followed.

- a. All surfaces must be kept clean with water and a mild soap solution.
- b. Water left on units for extended periods will damage surface. The finish must be wiped dry following cleaning.
- c. In high humidity areas, the room must be properly ventilated.
- d. Complete Care & Maintenance instructions are available at www.asi-accuratepartitions.com.

11 PRE-PACKAGED HARDWARE KITS

For your convenience and ease of installation, this shipment contains pre-packaged hardware for all standard toilet partition layouts. The packages are numbered as follows and should be used as shown on the diagram.

Figure 11

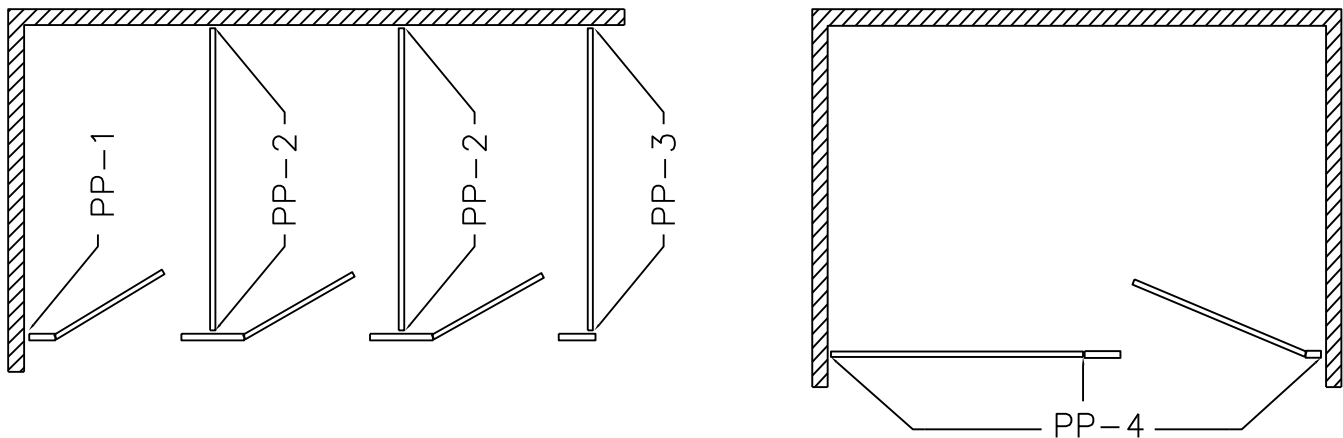

- PP-1 Hardware Pre-Pack #1 - Pilaster to Wall
- PP-2 Hardware Pre-Pack #2 - Intermediate Pilaster to Panel to Wall
- PP-3 Hardware Pre-Pack #3 - End Pilaster to Panel to Wall
- PP-4 Hardware Pre-Pack #4 - Complete Alcove Hardware

ASI Accurate Partitions

CEILING HUNG

USE THESE SIZES FOR DRILLING (ALL FASTENERS ARE T27 PIN HEAD TORX)

- #9 drill for #14 x 5/8" sheet metal screws
- 1/4" high speed drill for hinge and stop/keeper thru bolts
- 1/4" carbide drill for conical anchors
- 7/16" high speed steel drill for 3/8" threaded rod

1 INSPECTION

The components for this project have been custom fabricated. They were inspected at the factory and all workmanship is guaranteed. Before beginning work, the units should be inspected. If damage occurred in transit, report immediately to the freight company or other agencies that may have caused the damage.

2 LAYOUT

- a. Verify room dimensions and check all materials and hardware.
- b. Exposed beam installation: Strike a chalk line on beam parallel to plumbing wall to mark center of pilasters. Dimension from rear wall is 5/8" less than overall depth on the shop drawings. Example: standard 60" stall requires 59 5/8" centerline.
- c. Establish and mark centerline between water closets on the back wall, thereby locating center panels. Mark wall bracket elevations at 18" and 64" above floor at center of panels and wall pilaster(s), adjusting as required for grout lines.
- d. Begin at side wall and lay out pilasters on the beam/ceiling centerline using the bolt layout dimension shown on the shop drawings. Note: bolts are 1" in from each edge of pilaster.
- e. Transfer panel centers on wall to beam/ceiling centerline, thereby locating center of panel on pilaster. Stand pilasters against wall (protecting wall and floor as necessary) in order as shown on shop drawings. Locate hinge holes to the left or right as viewed from inside toilet compartment. Mark bracket locations 6" and 52" up from bottom of pilaster. Transfer panel centers from beam/ceiling layout to pilaster. Note: if panel is not centered on pilaster, make sure dimensions are marked correctly; example 6" from left and 4" from right.

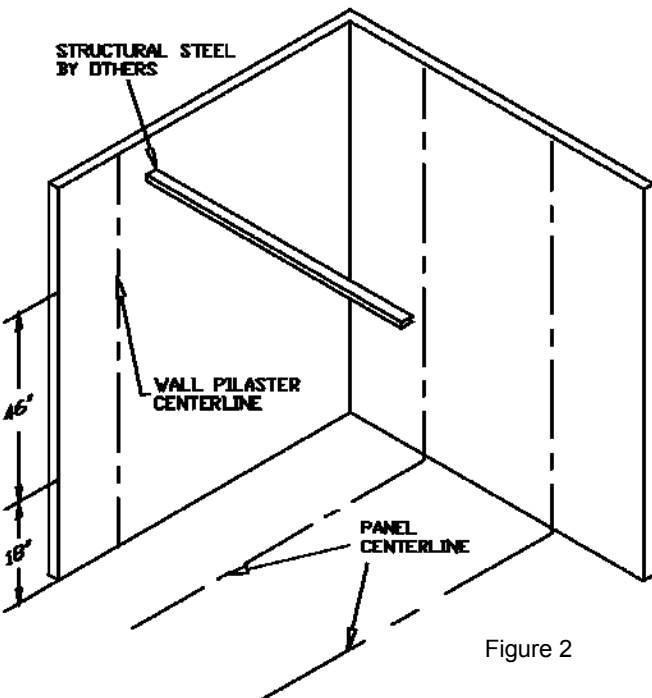

Figure 2

3 WALL BRACKETS & CEILING STUDS

- a. Mark bracket hole locations using appropriate bracket ("F" bracket for wall pilaster and end panels, "W" bracket for intermediate panels and "U" brackets on pilasters) as template.
- b. Drill appropriate size holes, 1/4" for walls and #9 on pilasters (Note: use a "stop" on drill bit to prevent dimpling pilaster face). Before proceeding, confirm that the backing of the walls is adequate to support secure mounting of the toilet compartments.
- c. Attach brackets to masonry walls using #12 x 2 1/2" sheet metal screws and conical anchors. If fastening to plaster or dry wall, use toggle bolts or mollies (supplied by others). Attach "U" brackets to pilasters using #14 x 5/8" sheet metal screws.
- d. For an exposed beam, drill 7/16" hole and install threaded rod, using washers and nuts provided.
- e. For beam above finished ceiling, drill 5/16" hole and thread with 3/8" x 16 tap. In either case, allow threaded rod to project downward a minimum of 2 1/2" below the finished ceiling. Place trim clip on threaded rod and draw up tight to exposed beam or finished ceiling with hex nut.

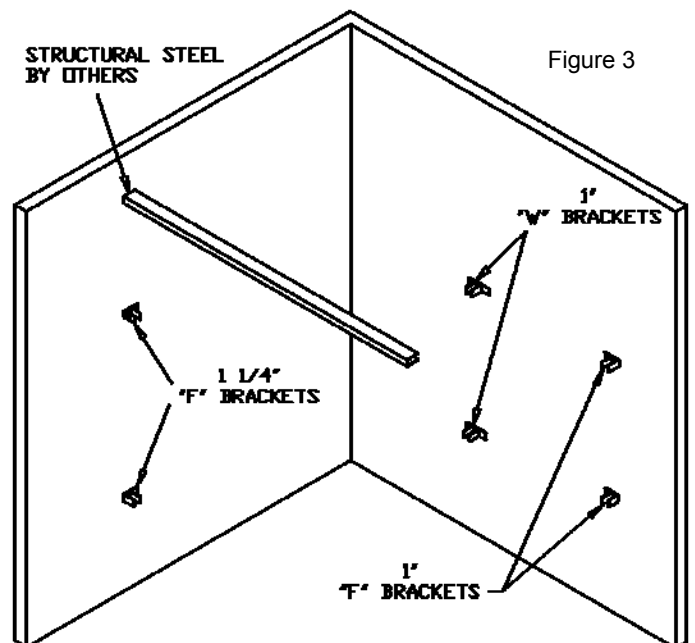

Figure 3

CEILING HUNG

4 ERECTION OF PILASTERS & PANELS

- Slide stainless steel trim over top of pilaster and leave approximately 5" down from top.
- Place washer, square spacer nut, and locking nut on one of the threaded studs. Position the slotted end of the pilaster mounting foot onto the spacer nut. This will help support the pilaster while installing the washer, square spacer nut and lock nut on the other stud. Snug both locking nuts up to the pilaster mounting foot.
- Repeat steps for remaining pilasters.
- Using a carpenter's level, verify that bottoms of pilasters are level.
- Place panel between wall brackets and on adjustable support (block and wedge) approximately 12" above floor. Note any special panel requirements, example: grab bar reinforcement, accessory cut outs, etc.
- Hold pilaster so that the bottom is even with the bottom of the panel and the front edge of panel is tight to the "U" brackets. Fasten to "U" brackets with #14 x 5/8" sheet metal screws. Level panel and fasten to wall brackets. Install remaining panels.
- With carpenter's level, use leveling nuts and locking nuts to plumb pilasters so that door openings are true. Verify door opening sizes. Make sure locking nuts are tight.
- Fasten wall pilaster to brackets using #14 x 5/8" sheet metal screws.
- Slide pilaster base trim to ceiling to lock with trim clip.

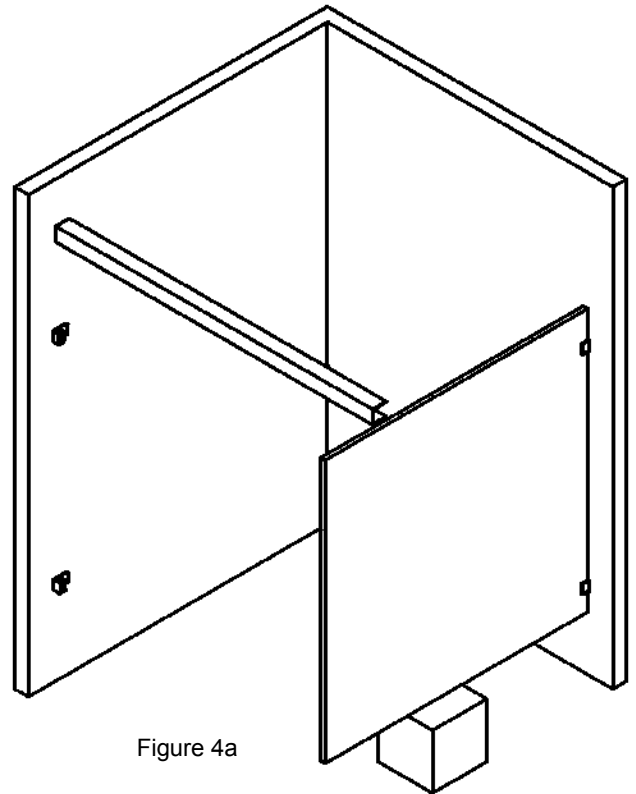

Figure 4a

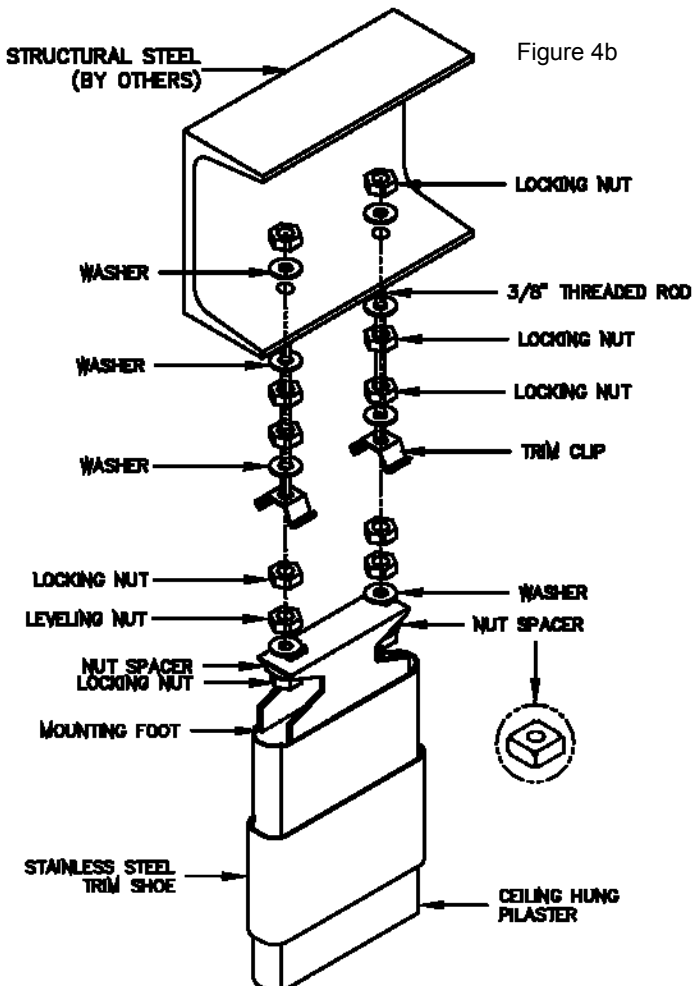

Figure 4b

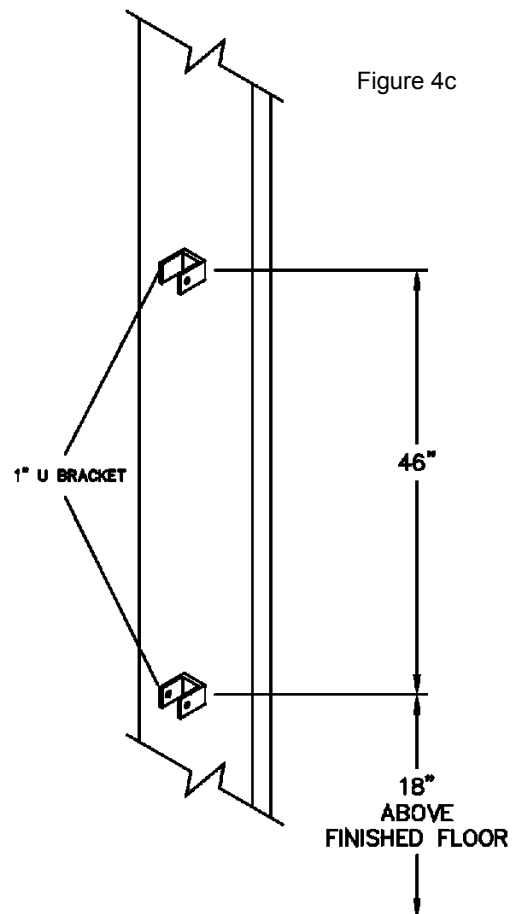

Figure 4c

5 DOOR HANGING AND ASSEMBLY

- a. Attach top and bottom hinge brackets to pilaster with thru bolts (4-total). If pilasters were not pre-drilled at the factory, use dimensions shown in Figure 5a as a drilling ($\frac{1}{4}$ " bit) guide.
- b. Assemble cam pintle, external tooth washer, internal tooth washer, and $\frac{1}{2}$ " hex nut to the bottom hinge bracket as shown in Figure 5a and hand-tighten (to be wrench-tightened later).
- c. Insert box cam into bottom door casting as shown in Figure 5a, with short key pointing toward hinge side (edge) of door.
- d. Set door onto bottom hinge cam pintle. Bring door up so the top hinge casting is in line with the top hinge bracket as shown in Figure 5a. Insert the top hinge pintle and tap it down so it's flush with the top of the door.
- e. Set resting position of door. Hold door firmly in desired resting position (typically 20 degrees open for inswing doors and closed for outswing doors and all accessible compartment doors, regardless of swing) and wrench-tighten the $\frac{1}{2}$ " hex nut under bottom hinge bracket.
- f. Mount external plate and knob. Remove clear plastic retainer holding spring washer in place on the post of the external plate. Insert the external plate into door as shown in Figure 5b, with the shorter post inserted into the upper pocket of the internal latch mechanism. Mount the knob/handle on the inside of the door and engage it with both the center post and the shorter, off-center post of the external plate. Insert $\frac{1}{2}$ " shoulder screw with blue tip through the knob/handle and tighten until snug. Check for proper operation of knob and latch pin before final tightening.
- g. Locate strike/keeper on the latch-side pilaster so the latch pin engages with it when the door is closed. Drill ($\frac{1}{4}$ " bit) mounting holes and secure strike/keeper to pilaster using thru bolt (1), with black rubber bumper facing out for outswing doors and in for inswing doors.
- h. Mount coathook/bumper near center of door and 34"- 48" above the floor with #10 x $\frac{3}{4}$ " sheet metal screws (drill holes with $\frac{1}{8}$ " bit).
- i. Mount door pulls with 1- $\frac{1}{4}$ " step bolts (drill holes with $\frac{1}{4}$ " bit) to both sides of all outswing doors and accessible compartment doors, near the latch and no more than 48" above floor.
- j. Mount wall bumper for outswing doors that are hinged next to a wall using conical anchor (drill hole with $\frac{1}{4}$ " bit) and 1" sheet metal screw.

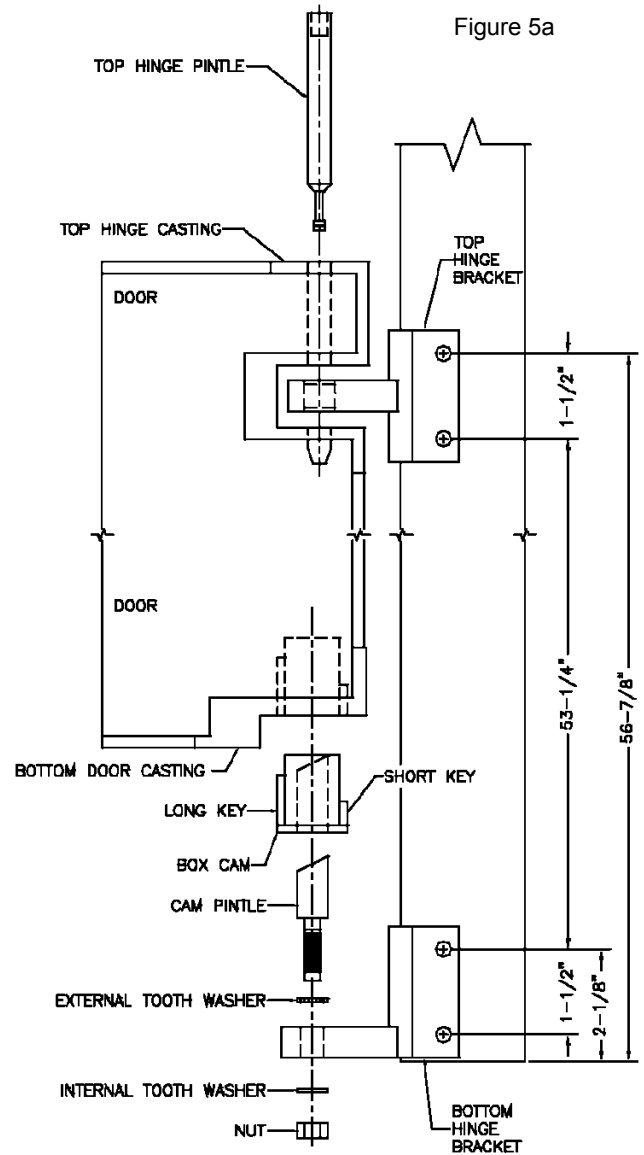

Figure 5a

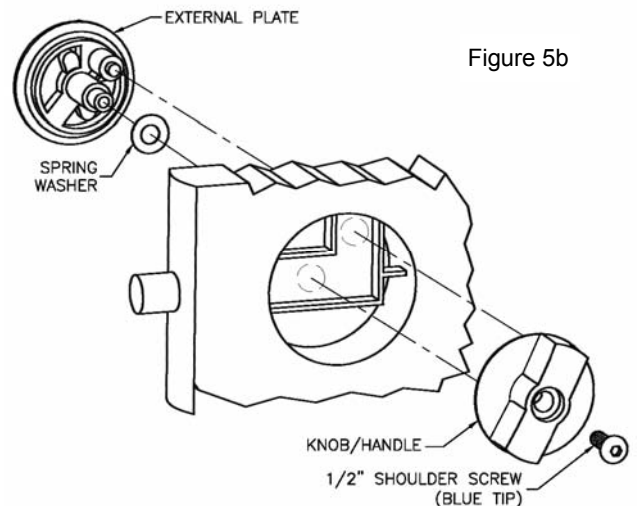

Figure 5b

CEILING HUNG

6 CARE AND MAINTENANCE

In order to provide toilet partitions with the proper care and maintenance, the following instructions must be followed.

- a. All surfaces must be kept clean with water and a mild soap solution.
- b. Water left on units for extended periods will damage surface. The finish must be wiped dry following cleaning.
- c. In high humidity areas, the room must be properly ventilated.
- d. Refer to www.accuratepartitions.com for complete Care and Maintenance instructions.

7 PRE-PACKAGED HARDWARE KITS

For your convenience and ease of installation, this shipment contains pre-packaged hardware for all standard toilet partition layouts. The packages are numbered as follows and should be used as shown on the diagram.

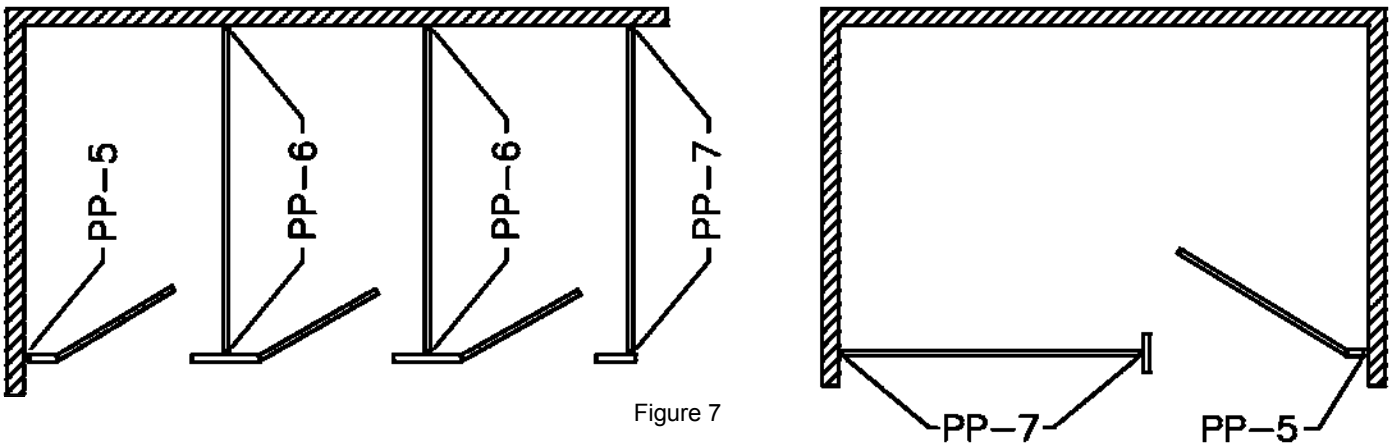

Figure 7

BRACKET PRE-PACK KITS

- PP-5 Bracket Pre-Pack #5 Kit - Pilaster to Wall
- PP-6 Bracket Pre-Pack #6 Kit - Intermediate Pilaster to Panel to Wall
- PP-7 Bracket Pre-Pack #7 Kit - End Pilaster to Panel to Wall, Alcove Intermediate Pilaster to Panel to Wall

CEILING BOLT & FASTENER PRE-PACK KITS

- CB-1 $\frac{3}{8}$ " Threaded Rod With Washers and Hex Nuts
- CB-2 $\frac{3}{8}$ " Hex Nuts, Washers, and Trim Shoe Clips

FLOOR MOUNTED

USE THESE SIZES FOR DRILLING (ALL FASTENERS ARE T27 PIN HEAD TORX)

#9 drill for #14 x 5/8" sheet metal screws

1/4" high speed drill for hinge and stop/keeper thru bolts

1/4" carbide drill for conical anchors

3/8" carbide drill for 3/8" x 5" wedge anchors

1 INSPECTION

The components for this project have been custom fabricated. They were inspected at the factory and all workmanship is guaranteed. Before beginning work, the units should be inspected. If damage occurred in transit, report immediately to the freight company or other agencies that may have caused the damage.

2 LAYOUT

- Review the layout drawings and package lists that have accompanied this job.
- Establish and mark pilaster center line from back wall as shown in Figure 2.
- Establish and mark panel center lines for wall brackets based on stall widths shown on drawings. Note: **panel center lines will probably not coincide with the centers of the pilasters.**
- Establish pilaster floor fastener locations from side wall according to shop drawings. (Note floor fasteners are located 1" from edges of pilaster).
- Mark wall bracket holes using brackets as templates.
- Drill holes for wall brackets and floor fasteners of appropriate size for fasten-

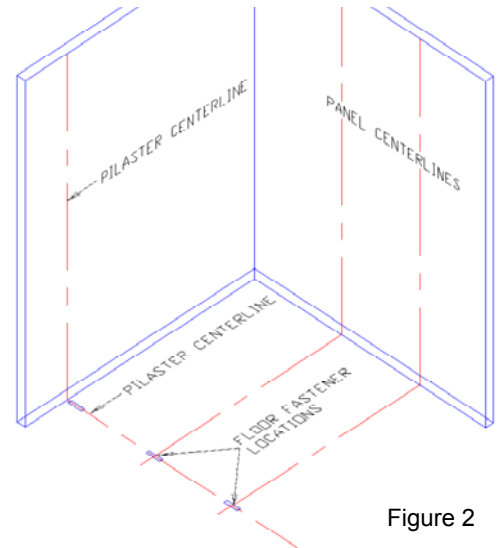

Figure 2

3 WALL BRACKETS & FLOOR ANCHORS

- Before proceeding, confirm that backing of wall and floor is adequate to support secure mounting of the toilet compartments.
- Mount wall brackets using screws provided and conical anchors if backing is not present.
- Insert wedge anchors into floor so that studs project 2" above floor. Place trim clip and flat washer on studs and draw up tight with hex nut. Place second nut and washer on studs, adjusting as required so that they are level across the room. See Figure 6 for details.

4 POSITION PANEL

- Place panel on a support 12" above the floor.
- Set it into wall brackets, but do not fasten panel at this time.

Figure 3

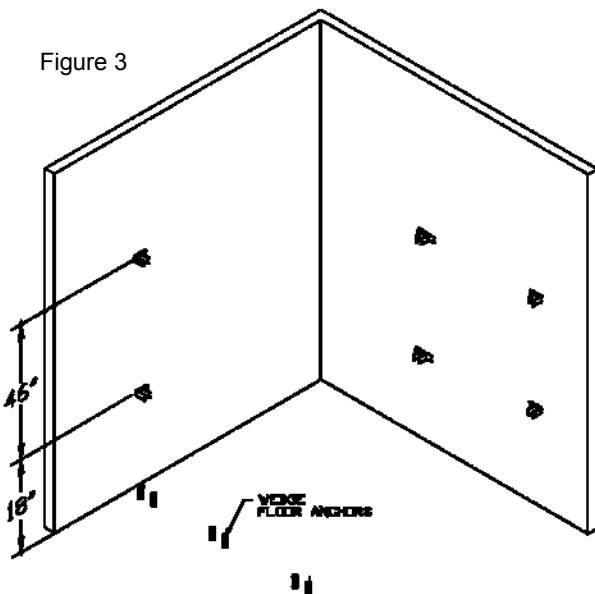
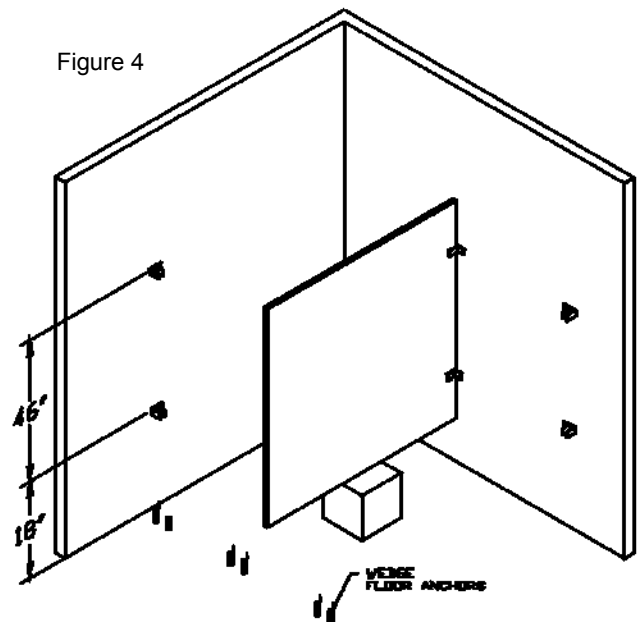

Figure 4



FLOOR MOUNTED

5 PILASTER PREPARATION

- Align U-brackets in position on rear of pilasters. Refer to layout drawings.
- Fasten U-brackets to pilasters with screws.
- Pilasters at wall do not require U-brackets, but should be prepared for wall (and floor fastening) as required by compartment layout. If floor fastening is omitted, three wall brackets should be used.

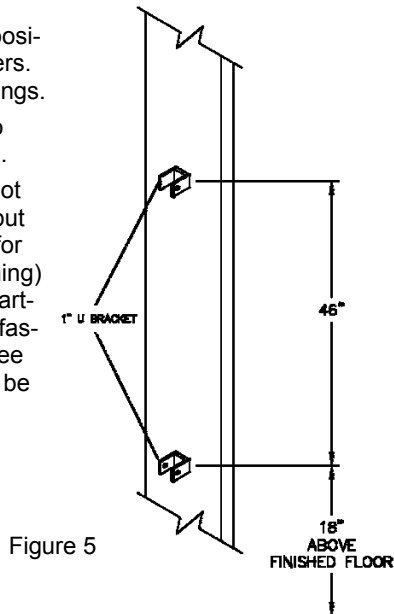

6 INSTALL PILASTER

- Slide stainless steel shoe carefully over mounting end of pilaster and leave approximately 5" above end.
- Place appropriate pilaster over the studs already positioned in the floor.
- Place square spacer nut and locking nut on stud and snug to pilaster anchoring channel.

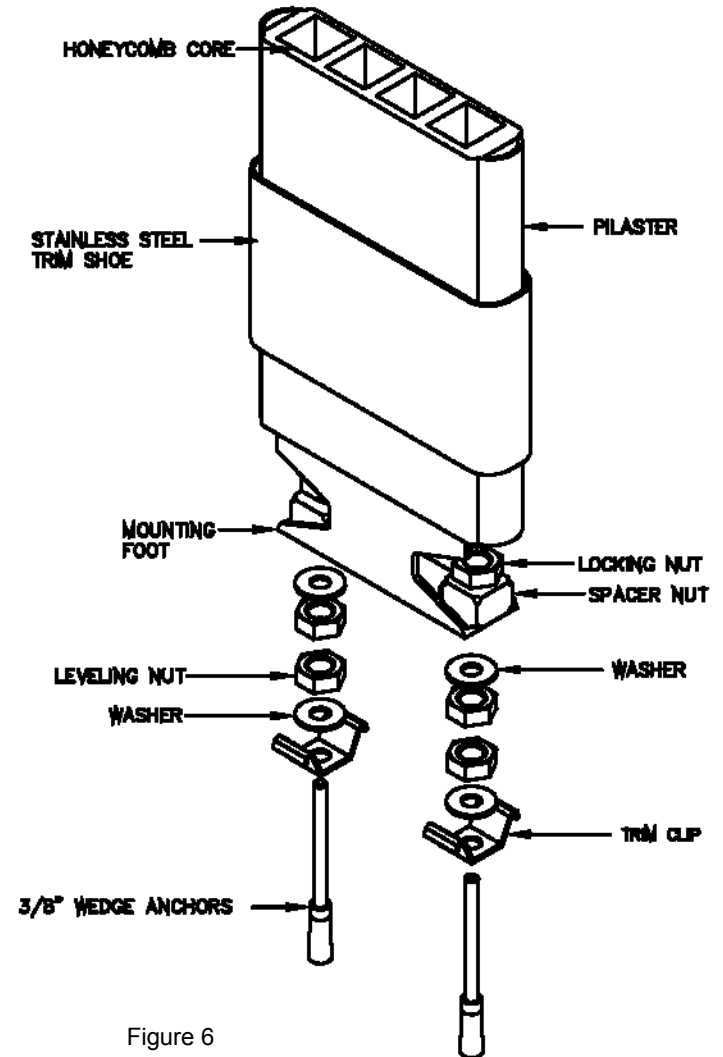

Figure 6

7 SECURING PILASTERS TO PANELS

- Pilasters must be both plumb and level.
- Hold pilaster so that the top is even with the top of the panel and the front edge of the panel is tight to the U-brackets. Fasten U-brackets to panel with 5/8" sheet metal screws. DO NOT fasten panel to back wall at this time.
- Repeat steps for remaining pilasters/panels. Follow steps 6a, 6b and 6c for wall pilasters.

8 PANEL FASTENING

- Confirm door openings and verify that edge of pilasters line up with floor layouts.
- Using a carpenter's level, verify that the tops of pilasters are level. Adjust leveling nuts if required.
- With carpenter's level, use leveling nuts and locking nuts to plumb pilasters so that door openings are true. Make sure locking nuts are tight.
- Slide stainless steel shoe down to floor level, firmly engaging shoe clips.
- Place a carpenter's level on top of panel and wedge out from rear wall until level. Attach panel to wall brackets and pilaster to wall brackets using #14x5/8" sheet metal screws.
- Remove panel support device.
- When installed correctly, the tops of the pilasters, panels and doors (in a closed position) will be level and even.

9 DOOR HANGING AND ASSEMBLY

- a. Attach top and bottom hinge brackets to pilaster with thru bolts (4-total). If pilasters were not pre-drilled at the factory, use dimensions shown in Figure 9a as a drilling ($\frac{1}{4}$ " bit) guide.
- b. Assemble cam pintle, external tooth washer, internal tooth washer, and $\frac{1}{2}$ " hex nut to the bottom hinge bracket as shown in Figure 9a and hand-tighten (to be wrench-tightened later).
- c. Insert box cam into bottom door casting as shown in Figure 9a, with short key pointing toward hinge side (edge) of door.
- d. Set door onto bottom hinge cam pintle. Bring door up so the top hinge casting is in line with the top hinge bracket as shown in Figure 9a. Insert the top hinge pintle and tap it down so it's flush with the top of the door.
- e. Set resting position of door. Hold door firmly in desired resting position (typically 20 degrees open for inswing doors and closed for outswing doors and all accessible compartment doors, regardless of swing) and wrench-tighten the $\frac{1}{2}$ " hex nut under bottom hinge bracket.
- f. Mount external plate and knob. Remove clear plastic retainer holding spring washer in place on the post of the external plate. Insert the external plate into door as shown in Figure 9b, with the shorter post inserted into the upper pocket of the internal latch mechanism. Mount the knob/handle on the inside of the door and engage it with both the center post and the shorter, off-center post of the external plate. Insert $\frac{1}{2}$ " shoulder screw with blue tip through the knob/handle and tighten until snug. Check for proper operation of knob and latch pin before final tightening.
- g. Locate strike/keeper on the latch-side pilaster so the latch pin engages with it when the door is closed. Drill ($\frac{1}{4}$ " bit) mounting holes and secure strike/keeper to pilaster using thru bolt (1), with black rubber bumper facing out for outswing doors and in for inswing doors.
- h. Mount coathook/bumper near center of door and 34"- 48" above the floor with #10 x $\frac{3}{4}$ " sheet metal screws (drill holes with $\frac{1}{8}$ " bit).
- i. Mount door pulls with 1- $\frac{1}{4}$ " step bolts (drill holes with $\frac{1}{4}$ " bit) to both sides of all outswing doors and accessible compartment doors, near the latch and no more than 48" above floor.
- j. Mount wall bumper for outswing doors that are hinged next to a wall using conical anchor (drill hole with $\frac{1}{4}$ " bit) and 1" sheet metal screw.

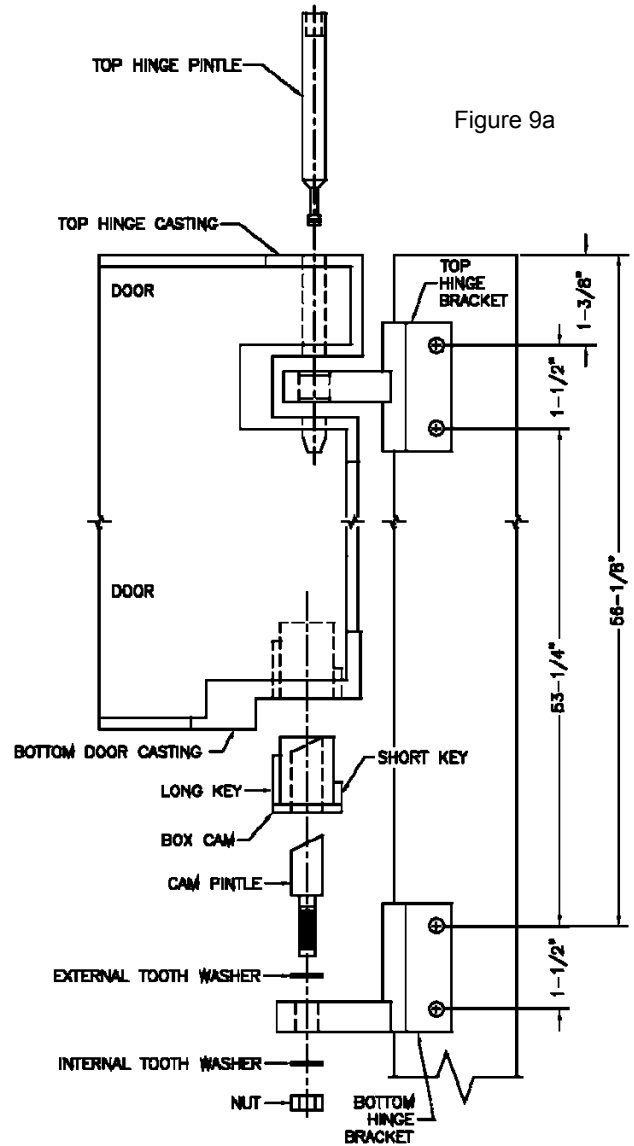

Figure 9a

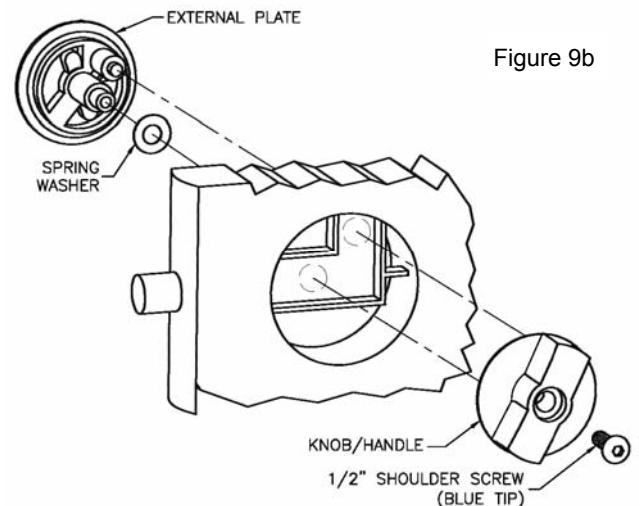

Figure 9b

FLOOR MOUNTED

10 CARE AND MAINTENANCE

In order to provide toilet partitions with the proper care and maintenance, the following instructions must be followed.

- a. All surfaces must be kept clean with water and a mild soap solution.
- b. Water left on units for extended periods will damage surface. The finish must be wiped dry following cleaning.
- c. In high humidity areas, the room must be properly ventilated.
- d. Refer to www.asi-accuratepartitions.com for complete Care and Maintenance instructions.

11 PRE-PACKAGED HARDWARE KITS

For your convenience and ease of installation, this shipment contains pre-packaged hardware for all standard toilet partition layouts. The packages are numbered as follows and should be used as shown on the diagram.

Figure 11

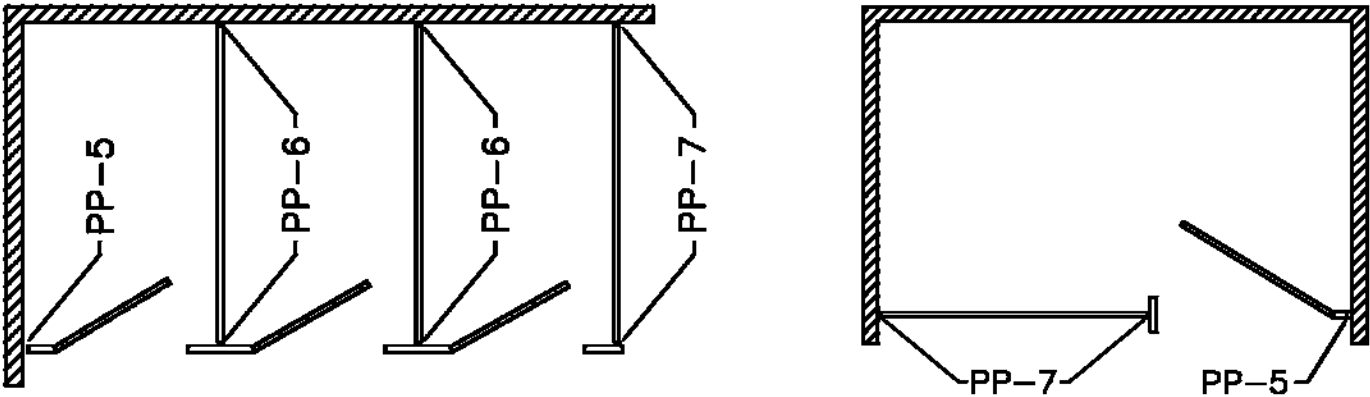

BRACKET PRE-PACK KITS

- PP-5 Bracket Pre-Pack #5 Kit - Pilaster to Wall
- PP-6 Bracket Pre-Pack #6 Kit - Intermediate Pilaster to Panel to Wall
- PP-7 Bracket Pre-Pack #7 Kit - End Pilaster to Panel to Wall, Alcove Intermediate Pilaster to Panel to Wall