

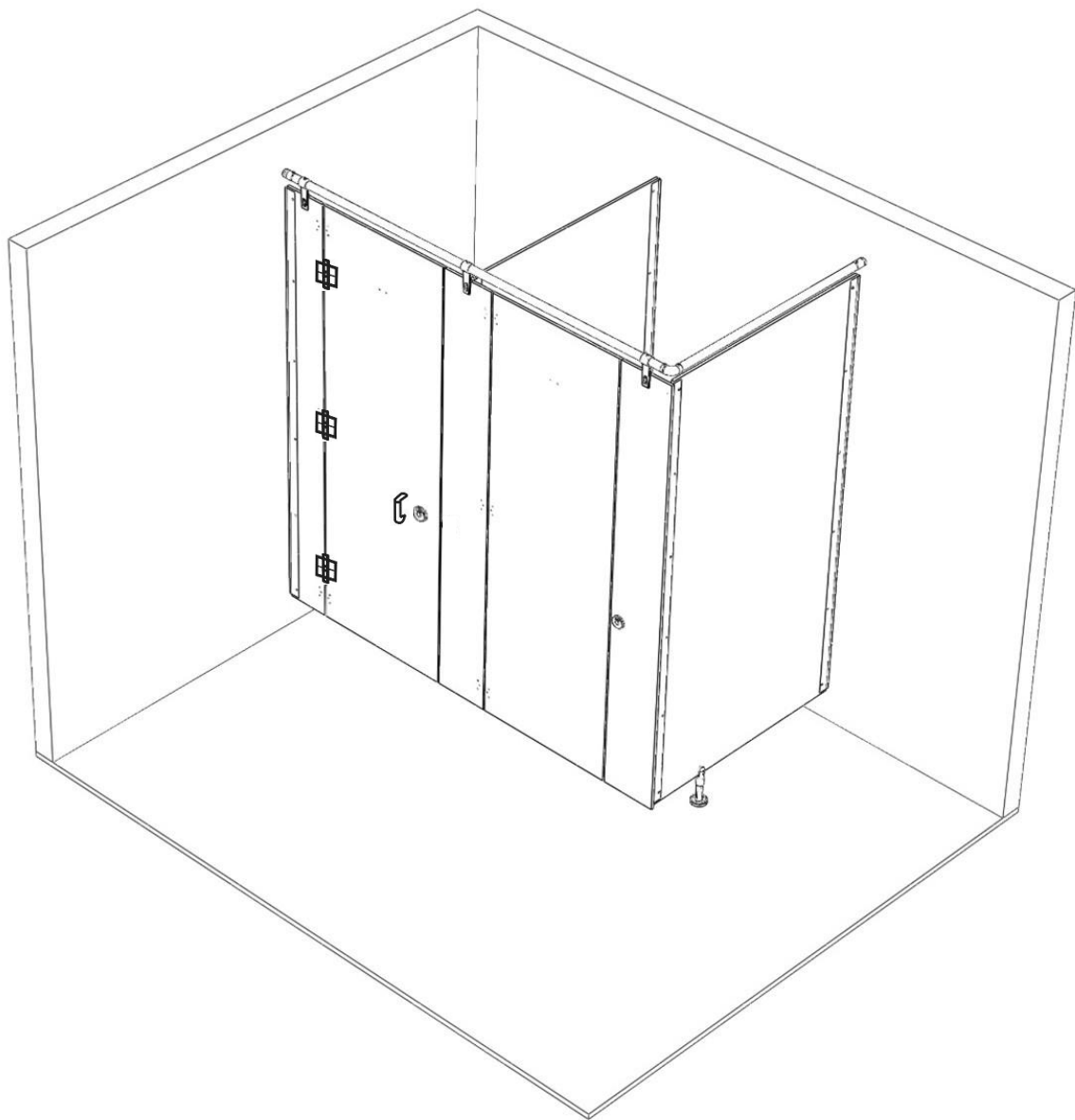

INSTALLATION INSTRUCTIONS FOR

ALPACO ELEGANCE PARTITIONS



160 Tower Drive, Burr Ridge, IL. 60527 Phone: (708) 442-6800
Fax: (708) 442-7439 Website: www.asi-accuratepartitions.com

Table of Contents

<u>Topic</u>	<u>Page</u>
Layout and Wall Brackets.....	2
Panel and Pilaster Preparation.....	3
Securing Components and Head Rail.....	4
Panel to Pilaster/Wall Assembly.....	5
Pilaster/Wall Assembly.....	6
Pilaster/Panel Alcove Assembly.....	7
Head Rail Connection Details.....	8
Head Rail Clips Connection Details.....	9
Door Hardware Inswing Assembly.....	10
Door Hardware Outswing Assembly.....	11
Latch Assembly.....	12
Hinge Assembly.....	13
Urinal Screen Assembly.....	14
Care and Maintenance of Bathroom Partitions.....	15

Required Tools

- Power Drill
- Angle Drill (for head rail)
- T-27 Pin Torx Driver
- Allen Wrench set
- 5/16" Masonry Drill Bit
- 1/4", #11/64, and #5/32 Drill Bits
(and others as needed)
- Drill Bit Stop
- 4' (or longer) Level
- 4", 6" or 9" support as required

Important

The components for this project have been custom fabricated. These components are guaranteed with respect to their manufacture and craftsmanship and were inspected at the factory.

Before beginning work, the units should be inspected. If damage occurred in transit, report immediately to the freight company or other agencies that may have caused the damage.

STEP 1:
LAYOUT

- A. **Before proceeding, confirm that the backings of the walls and floor are adequate to support the secure mounting of the ALPACO Classic units.**
- B. Review the layout drawings and package lists that have accompanied this order.
- C. Establish and mark panel center lines for wall brackets. See the accompanied fabrication drawings for compartment dimensions.
- D. Mark wall bracket holes using the brackets as templates. Depending on the pedestal height the bottom of the bracket should sit at 4 1/4", 6 1/4" or 9 1/4" above the floor.
- E. If installing an alcove, please see page 7 for details.

FIGURE 1

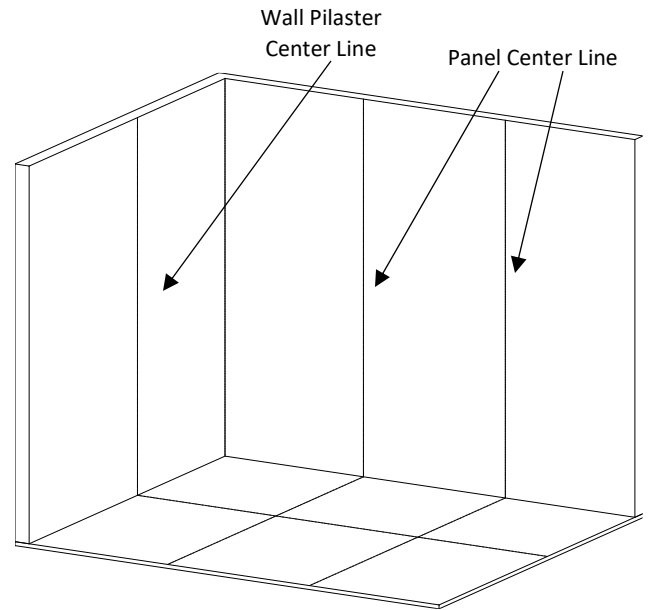

STEP 2: **WALL BRACKETS**

- A. Drill 1/4" diameter x 2.5" deep holes for the red plastic shields provided using a 1/4" drill bit. However, as site conditions vary, an assortment of bit sizes is recommended.
- B. Insert the anchoring devices into the walls, and secure the wall brackets.

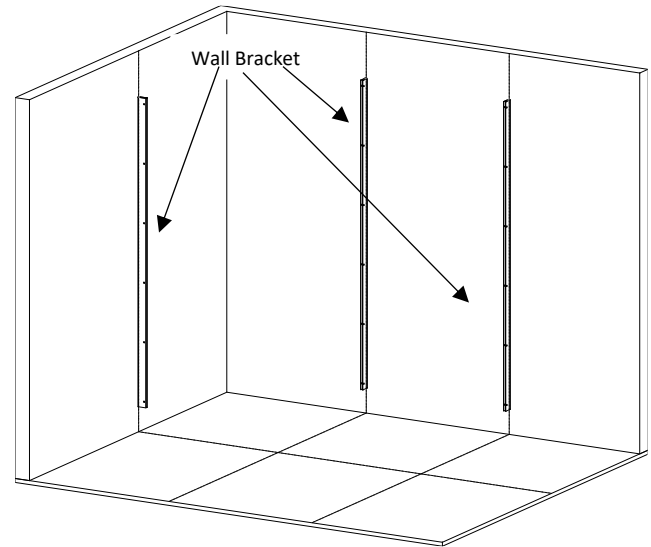
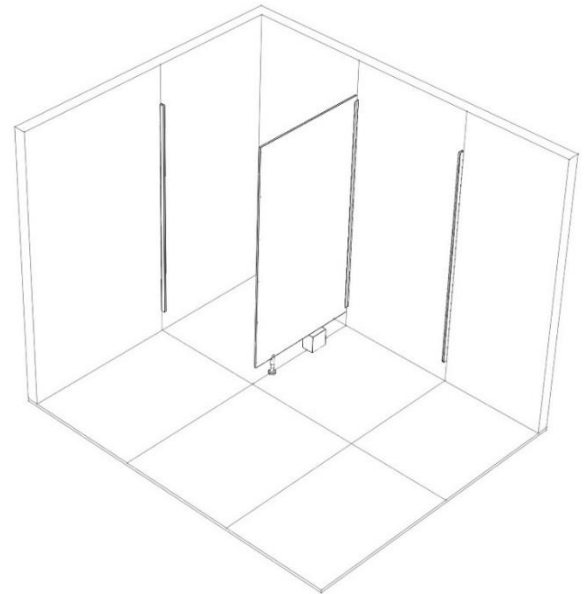

FIGURE 2

STEP 3: **POSITION PANEL**

FIGURE 3

- A. Assemble pedestal and adjust it to the desired height by turning clockwise or counterclockwise.
- B. Place the panel on a temporary support device. Set the panel into the wall bracket and unanchored pedestal.
- C. Adjust the gap between the panel and wall bracket.
- D. Plumb, level, and fasten the panel to the wall bracket.
- E. Remove the support device and ensure panels are level across the stalls.



STEP 4:

FIGURE 4

PILASTER PREPARATION

- A. **Note that each pilaster is labeled on its front and can be matched to the layout based on that label.** Align the U-brackets in position on rear of pilasters. Refer to layout drawings and make sure U-brackets are in alignment with wall brackets.
- B. Mark U-bracket holes using the wall brackets as templates. Drill 11/64" diameter x 7/16" deep holes for U-bracket fasteners (a #11/64" drill bit and drill bit stop are recommended).
Correct hole diameter and depth is critical.

Note: Reference pages 5, 6 & 7 as needed for the next 3 steps.

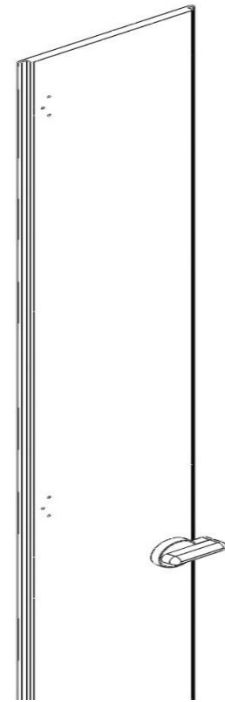

STEP 5:

SECURING PILASTERS AND PEDESTALS

- A. A temporary support device is highly recommended to place under each pilaster to assist in alignment.
- B. Plumb each pilaster and fasten the pilaster to the panel with U-brackets using through-bolts through the panel.
- C. Establish door openings as measured from the inner edge of one pilaster to the inner edge of the other pilaster.
- D. Mark holes on the floor for the pedestals. Drill floor and panel for each pedestal using a 5/16" masonry drill bit. Attach each pedestal to the floor and the panel.
- E. Remove the support device.

FIGURE 5

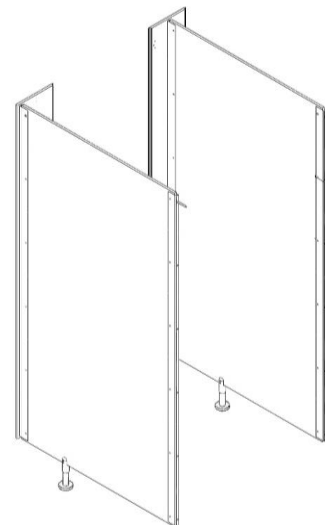

STEP 6: HEAD RAIL

- A. Plumb each pilaster.
- B. Verify door openings between pilasters prior to drilling holes in head rail. Holes for head rail clip and couplers are predrilled at the factory.
Head Rail must be cut to size.
- C. Attach the head rail (see figure 6 for head rail connections). **Tube should be seated fully into the connectors and drilled to accept fasteners using a #5/32" drill bit.**

See page 8 & 9 for detailed illustrations of the head rail components.



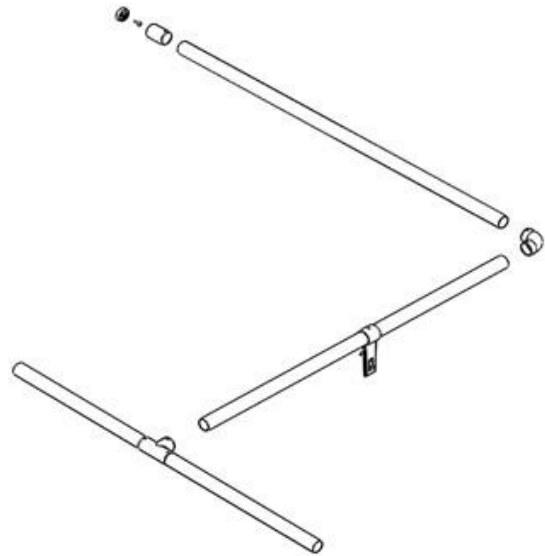



FIGURE 6



PANEL TO PILASTER/WALL ASSEMBLY

- A. Plumb panel and fasten panel to wall bracket with through-bolts. To facilitate the through-bolts, the holes of the panel should be drilled with a 1/4" drill bit through the panel.

HARDWARE LIST

PICTURE	DESCRIPTION	QTY
	#10-24 x 3/8" NUT	12
	#10-24 x 1/2" BOLT	12
	#12 x 2.5" WALL SCREW	6
	RED PLASTIC SHIELD	6
	"U" BRACKET	2
	#12 x 7/16" BRACKET SCREW	6



B. Plumb pilaster then fasten the panel to the pilaster bracket using through-bolts and barrel nuts.

PILASTER/WALL

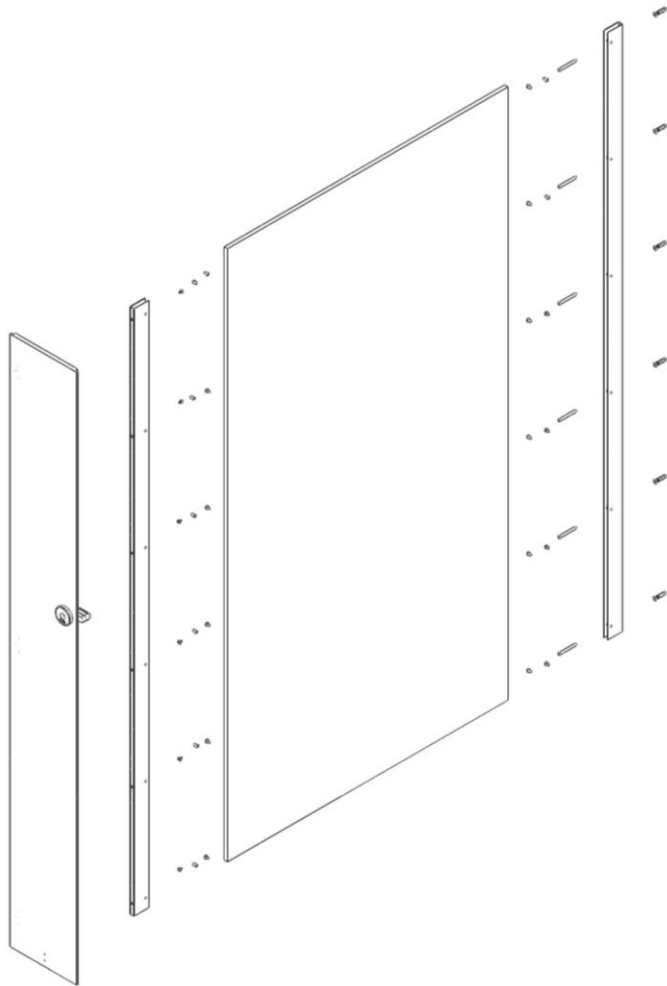

HARDWARE LIST

PICTURE	DESCRIPTION	QTY
	#12 x 2.5" WALL SCREW	6
	RED PLASTIC SHIELD	6
	"U" BRACKET	1
	#10-24 x 3/8" NUT	6
	#10-24 x 1/2" BOLT	6



FIGURE B

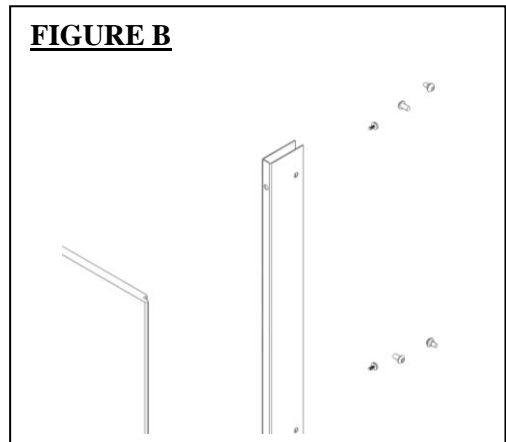





ASSEMBLY

A. Verify that the pilasters are both plumb and level before continuing.

B. Fasten the pilaster to the wall bracket using through-bolts and barrel nuts.

PILASTER/ PANEL ALCOVE

HARDWARE LIST

PICTURE	DESCRIPTION	QTY
	#10-24 x 3/8" NUT	24
	#10-24 x 1/2" BOLT	24
	#12 x 2.5" WALL SCREW	12
	RED PLASTIC SHIELD	12
	"U" BRACKET	4

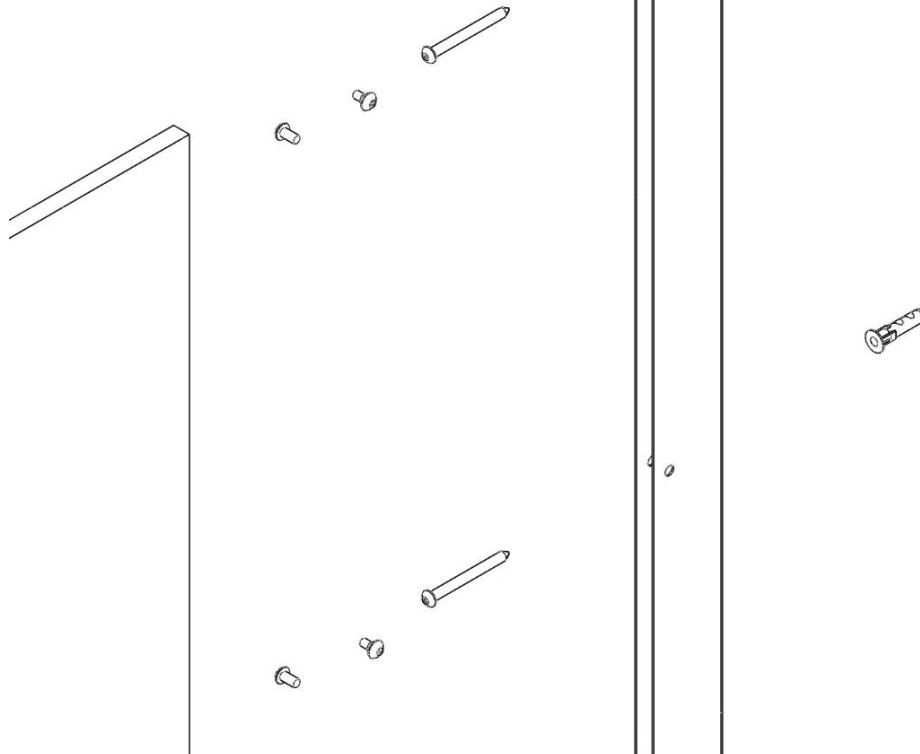

ASSEMBLY

A. For the perpendicular pilaster between two "U" brackets (the tee configuration), first use a through-bolt through the two "U" brackets to fasten the pilaster to the wall panel.

- B. If a standalone alcove is present, the tee configuration is replaced by two alcove brackets (Figure A).

Note: For door details, see pages 10 and 11.

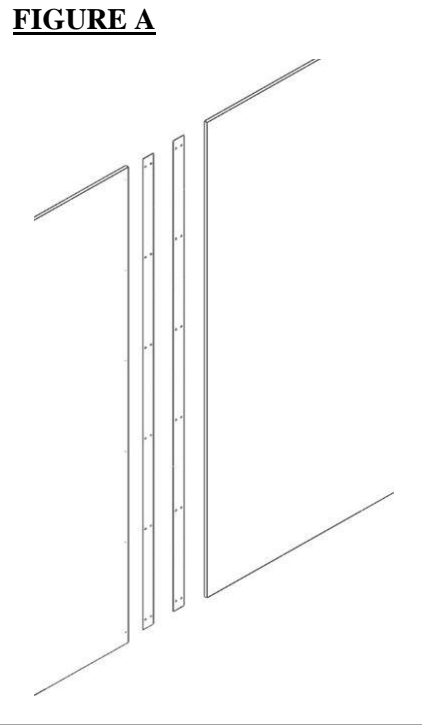
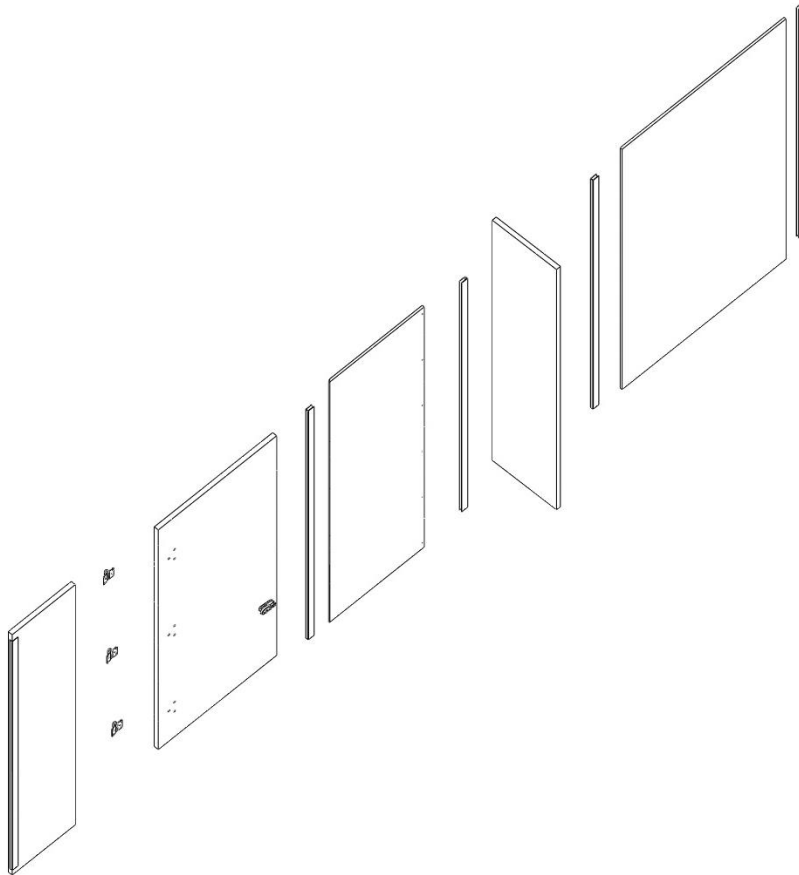

HEAD RAIL CONNECTIONS

**HEAD RAIL
TO WALL
CONNECTION**

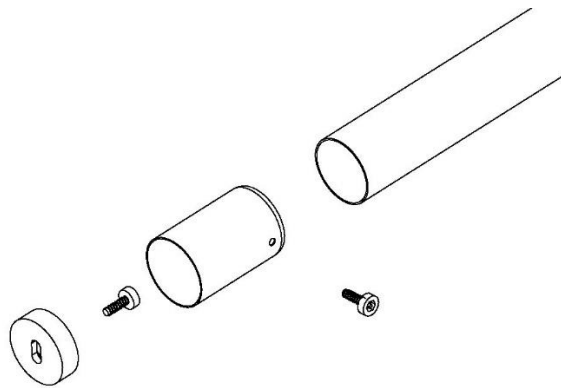

**HEAD RAIL
"T" CONNECTION**

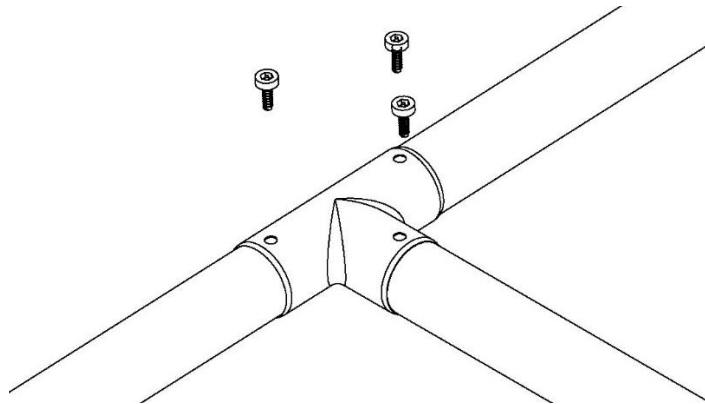

**HEAD RAIL
"L" CONNECTION**

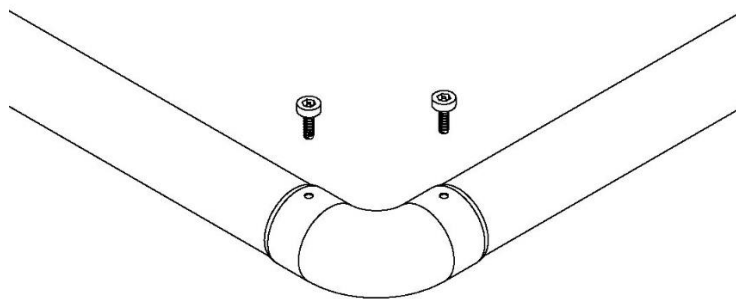

HEAD RAIL CLIPS

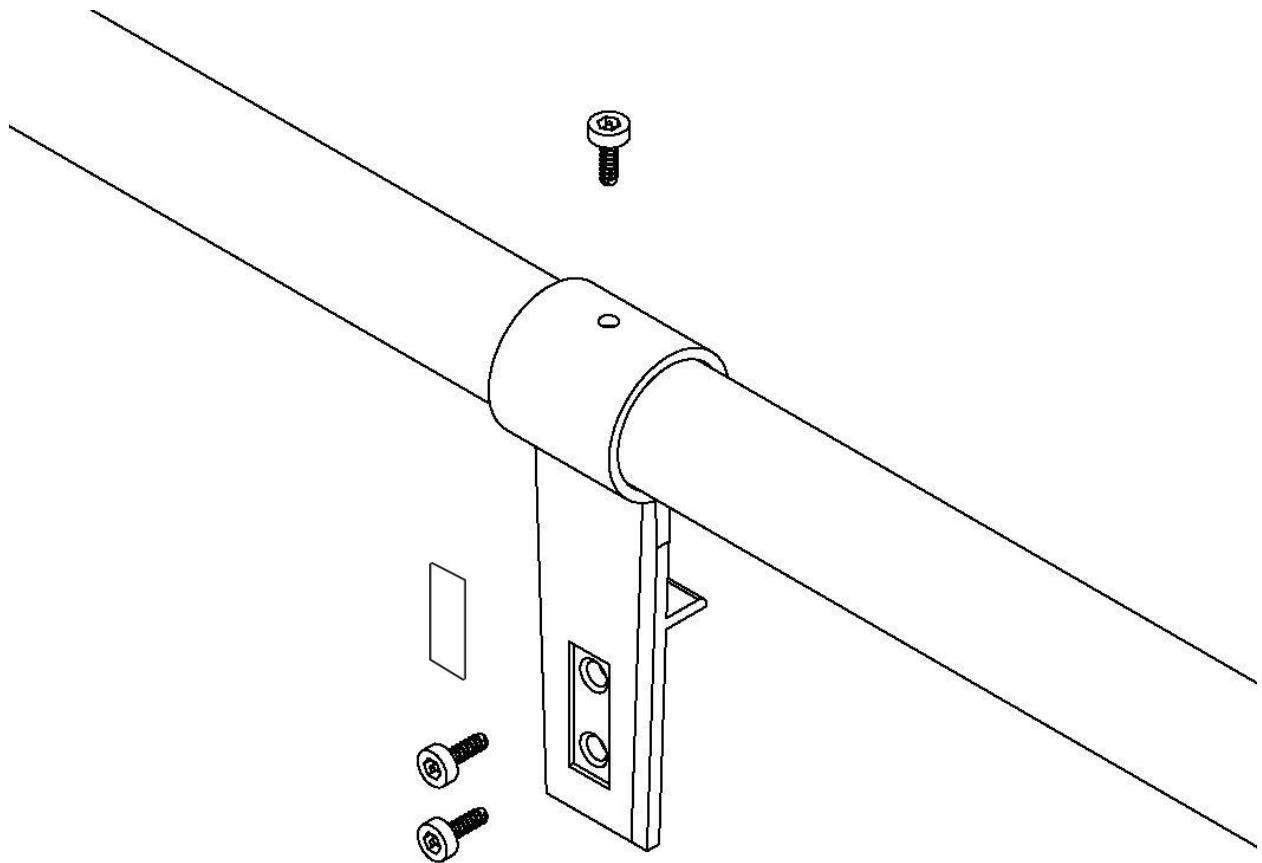

Note: Pilasters 8" or larger will be predrilled.

7" or less will not be predrilled.

A 11/64" drill bit will be needed to drill the holes at a depth of 7/16" deep.

Correct hole diameter and depth is very critical.

DOOR HARDWARE

ASSEMBLY - INSWING

- A. Place door on temporary support device.
Attach hinges to the pilaster & door using the #10 screws as shown in the hardware list.
- B. Drill for the coat hook with a 1 1/64" drill bit to a depth of 7/16". **Correct hole diameter and depth is very critical for correct installment.**
- C. There will be only one door pull provided per door.

Note: please see pages 12 and 13 for hinge and latch installation details, respectively.

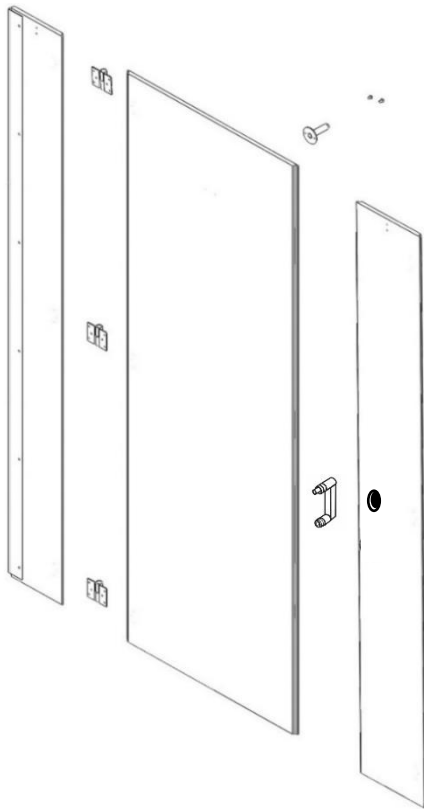

HARDWARE LIST



PICTURE	DESCRIPTION	QTY
	HINGE ASSEMBLY WITH COVER PLATE (0°) & (20°)	3
	#10 x 7/16" HINGE SCREWS	18
	COAT HOOK WITH TWO SCREWS	1
	DOOR PULL	1

FIGURE A





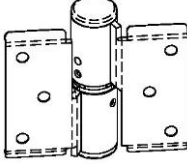

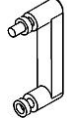
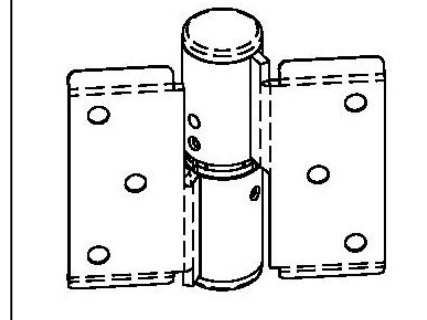
DOOR HARDWARE ASSEMBLY - OUTSWING

- A. All Doors will require 3 hinges.
- B. Install additional door bumper on the outside of the door as required.
- C. All hinges are cammed.
- D. **Holes will be predrilled for alignment.**

Note: If door is outswing or ADA compliant then there will be two door pulls provided per door.

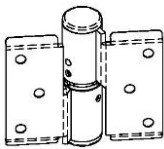
- E. The holes for the coat hook should be drilled to a depth of 7/16" with a 11/64" drill bit.
Correct hole diameter and depth is very critical for correct installment.



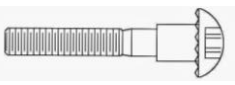

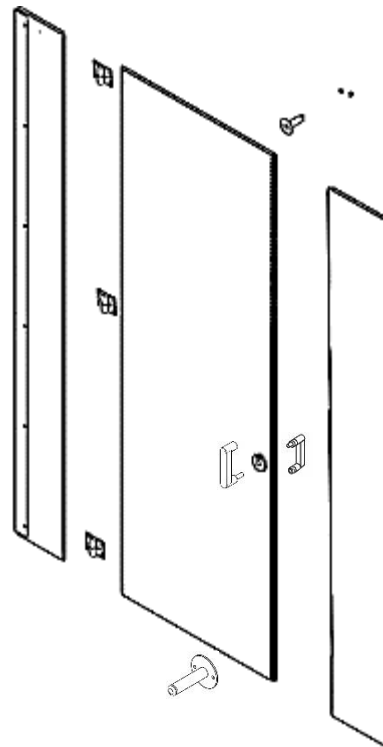
Note: please see pages 12 and 13 for hinge and latch installation details, respectively.

<u>HARDWARE LIST</u>		
PICTURE	DESCRIPTION	QTY
	HINGE ASSEMBLY WITH COVER PLATE (CAMMED)	3
	#10 x 0.4375" HINGE SCREWS	18
	OUTSWING BUMBER (COAT HOOK) TWO SCREWS	2
	DOOR HANDLES	1
	DOOR PULL BOLT	2

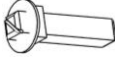

LATCH ASSEMBLY

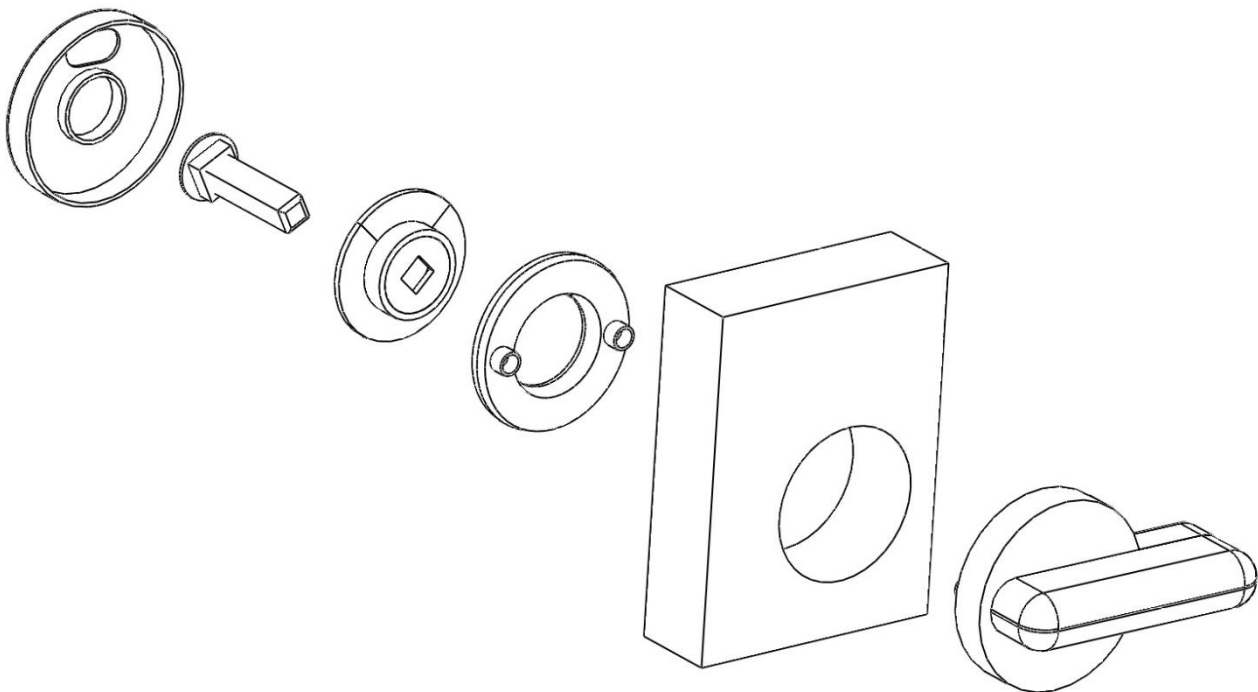

HARDWARE LIST

PICTURE	DESCRIPTION	QTY
	INDICATOR COVER WITH INSERT	1
	CENTER SHAFT	1
	INDICATOR DIAL	1
	INDICATOR DIAL PLACEMENT SLEEVE	1
	LATCH HANDLE	1
	#10-24 x 1/2" BOLT	2

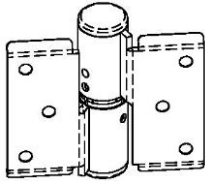
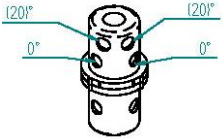

HINGE ASSEMBLY

- A. Cams are preset at an angle of 0°. ASI recommends using 0° angle because it also complies with Federal ADA codes and guidelines
- B. If changing the angle, use the Allen Wrench to detach the setscrew. Then rotate until hole line up with 20° as shown in the picture.
- C. Reinsert set screw in 20° hole.

<u>HARDWARE LIST</u>		
PICTURE	DESCRIPTION	QTY
	CAMMED HINGE	1
	SET SCREW	1
	#10 x 7/16" HINGE SCREWS	6
	COVER PLATE	2

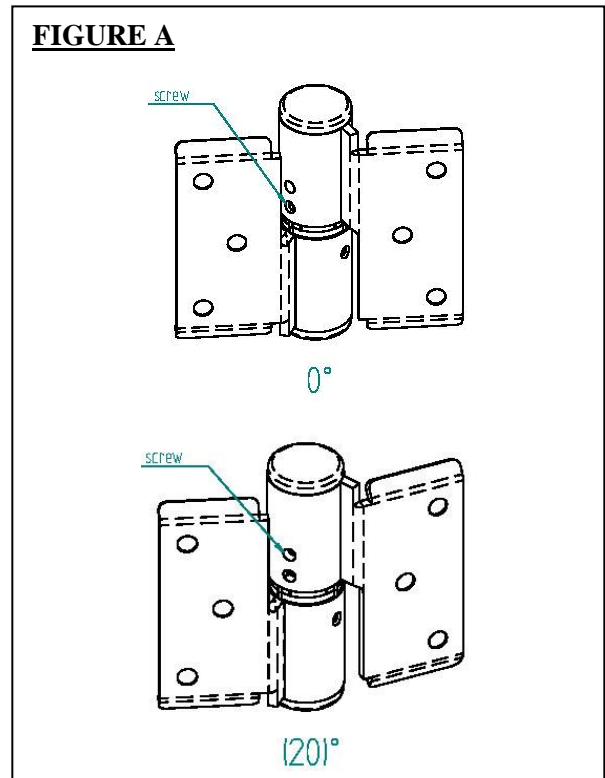





URINAL SCREEN

ASSEMBLY

- A. Before proceeding, confirm that the backing of the wall is adequate to support the mounting of urinal screens. Check shop drawings for layout.
- B. Insert plastic shields into the walls and secure wall brackets with 2.5" wall screws.
- C. Place urinal screen on a support device at desired height.
- D. Drill holes through the urinal screen to facilitate through-bolts.
Set the urinal screen into wall brackets and fasten.

HARDWARE LIST

PICTURE	DESCRIPTION	QTY
	#12 x 2.5" WALL SCREW	4
	RED PLASTIC SHIELD	4
	U/S "U" BRACKET	1
	#10-24 x 3/8" NUT	4
	#10-24 x 1/2" BOLT	4

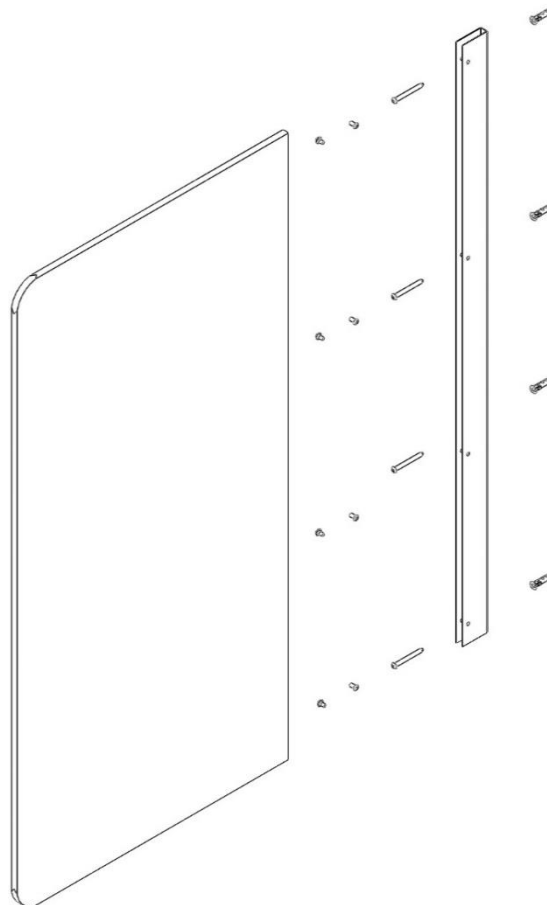

CARE AND MAINTENANCE OF

BATHROOM PARTITIONS

In order to provide bathroom partitions with proper care and maintenance, the following instructions must be followed:

- A. All surfaces must be kept clean with water and a mild soap solution only.
- B. In areas of high humidity, the rooms must be properly ventilated.
- C. “Hosing down” or wet-washing of these units may cause water adsorption and damage.
- D. For maximum protection, periodic application of any standard furniture wax will be beneficial.

WARNING

Under no circumstances should these components be subjected to:

- Abrasive powders or pads
- Bathroom cleaners
- Ceramic tile cleaners
- Solutions containing more than 1% by volume of ammonia
- Solutions containing acids or lye
- Solutions containing enzymes

Attention to work progress during new construction or renovation is paramount.

Some cleaning services may use agents for ceramics and tiles that will damage these components.